



kW	3.6
V	230
Hz	50/60



kg	10
----	----



mm	483x252x395h
----	--------------



EAN	8437006768238
-----	---------------



Características Generales

Bandeja de migas extraíble • Cuerpo en acero inoxidable • Resistencia blindada • Parrilla extraíble • Resistencia protegida por parrilla • Los modelos con temporizador incluyen posición fija • Interruptor por cada planta de resistencias.

General Characteristics

Removable crumb tray • Stainless steel body • Shielded heating elements • Removable grill • Resistance protected by grill • Models with timer includes fixed position • Switch at any resistor plant.

Caractéristiques Générales

Bac à miettes amovible • Corps en acier inoxydable • Résistance blindé • Grille amovible • Résistances protégées par des grilles • Les modèles avec minuteur de 15 minutes disposent d'une position fixe • Interrupteur à chaque niveau.

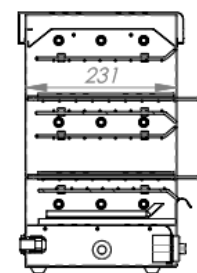
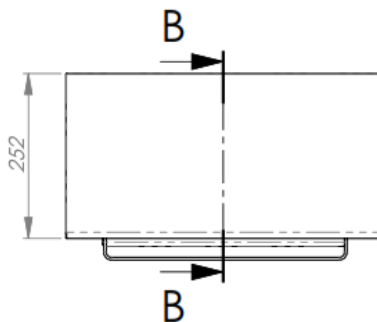
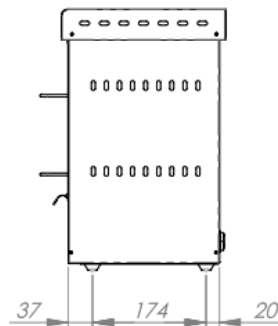
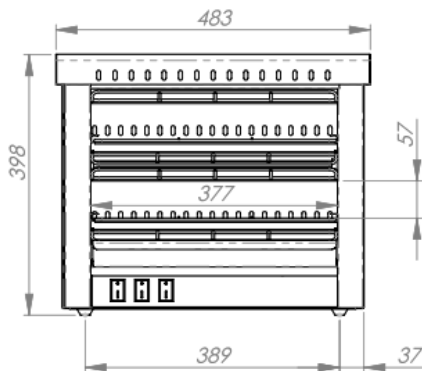

SECCIÓN B-B